

INSTITUTO DE ACUSTICA  
CENTRO DE TECNOLOGIAS FISICAS L.TORRES QUEVEDO”

REPORT

REF.-AC3-D6-99-11

YESYFORMA EUROPA  
Ctra. De Castellón. Km 3  
Polígono Industrial “SAN CARLOS, NAVE 2”  
50013-ZARAGOZA

This report concerns the analysis of sound absorption characteristics of the materials described below, in a position to diffuse sound field (reverberant chamber)

**1.- TESTED MATERIALS**

The product analyzed in this test, named PERFORADA, by the applicant firm is a registrable plaster ceiling , 20 mm thickness with round perforations 4 mm diameter, arranged in a square grid of 8 mm hand,. It comes in pieces of 59x59 cm<sup>2</sup>, panelling of mineral wool of 10 mm and 77 kg/m<sup>3</sup>, and a complex-shaped aluminum foil, fixed perimeter.

# SOUND ABSORPTION COEFFICIENT

According rule UNE-EN 20354

Applicant: YESYFORMA

Product identifier: Plaster ceiling tiles (PERFORADA) with rockwool and aluminium sheet.

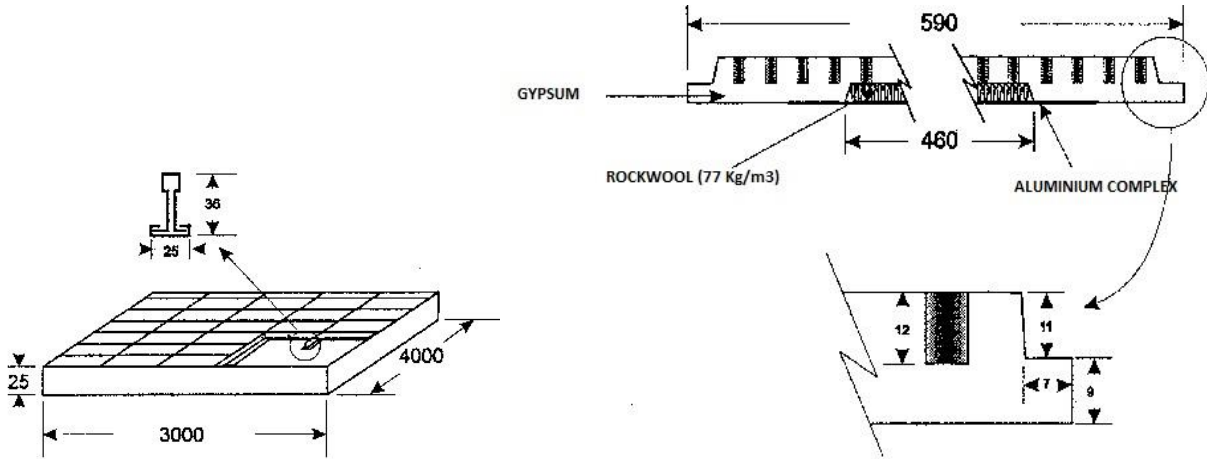

Room volume : 200 m<sup>3</sup>  
 Room surface: 210 m<sup>2</sup>  
 Test sample area (m<sup>2</sup>): 12 m<sup>2</sup>

Pressure: 935 mb  
 Temperature: 22°C  
 Test room humidity: 47%

f (Hz)	125	250	500	1000	2000	4000
$\alpha_s$	0.3	0.6	0.5	0.5	0.5	0.3

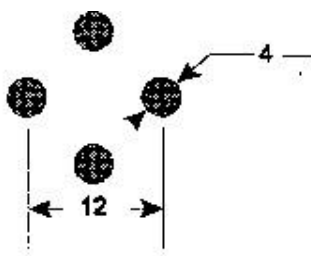
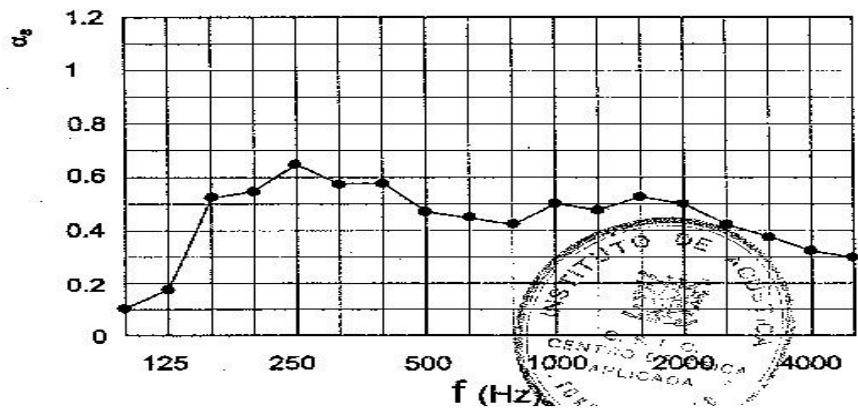

$\alpha_m = 0,49$

NRC=0,55

Report AC-3-D6-99 II  
 Madrid, the 29<sup>TH</sup> of  
 September 1999

INSTITUTO DE ACUSTICA  
 CETEF Leonardo Torres Quevedo

Materials Laboratory

