

INSTITUTO DE ACUSTICA  
CENTRO DE TECNOLOGIAS FISICAS L.TORRES QUEVEDO”

REPORT

REF.-AC3-D4-11

YESYFORMA EUROPA  
C/Tomás Edison  
Agrup. Nido, naves 27-28  
Polígono Industrial Cogullada

50014-ZARAGOZA

This report concerns the analysis of sound absorption characteristics of the materials described below, in a position to diffuse sound field (reverberant chamber)

**1.- TESTED MATERIALS**

The product analyzed in this test, named Shadow Edge, by the applicant firm is a registrable plaster ceiling , 21 mm thickness with round perforations 4.6 mm diameter, arranged in a square grid of 14 mm hand, with a central hole. It comes in pieces of 58x58 cm<sup>2</sup>, panelling of mineral wool of 10 mm and 82 kg/m<sup>3</sup>, and a complex-shaped aluminum foil, fixed perimeter.

# SOUND ABSORPTION COEFFICIENT

According rule UNE-EN ISO354

Applicant: YESYFORMA EUROPA

Product identifier: Plaster ceiling tiles (SHADOW EDGE) perforated with rockwool and aluminium sheet.

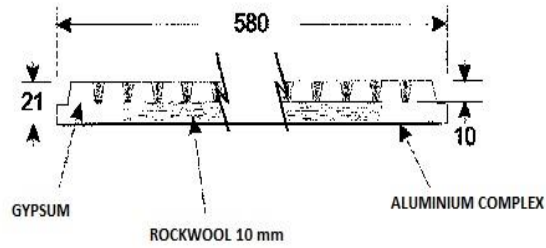
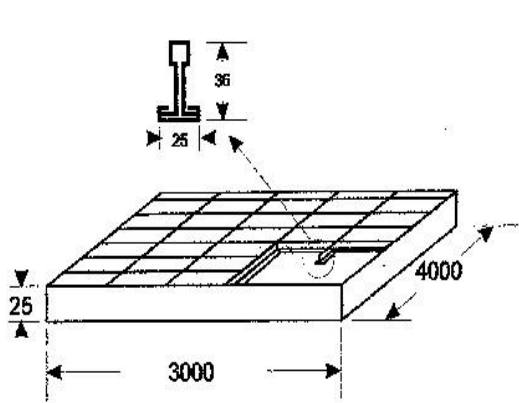

Room volume : 200 m<sup>3</sup>  
 Room surface: 210 m<sup>2</sup>  
 Test sample area (m<sup>2</sup>): 12 m<sup>2</sup>

Pressure: 1004 mb  
 Temperature: 15°C  
 Test room humidity: 52%

f (Hz)	125	250	500	1000	2000	4000
$\alpha_s$	0.35	0.75	0.65	0.6	0.55	0.35

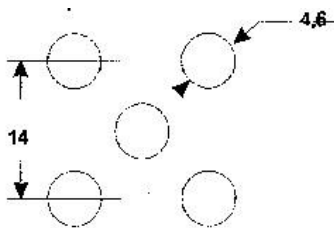
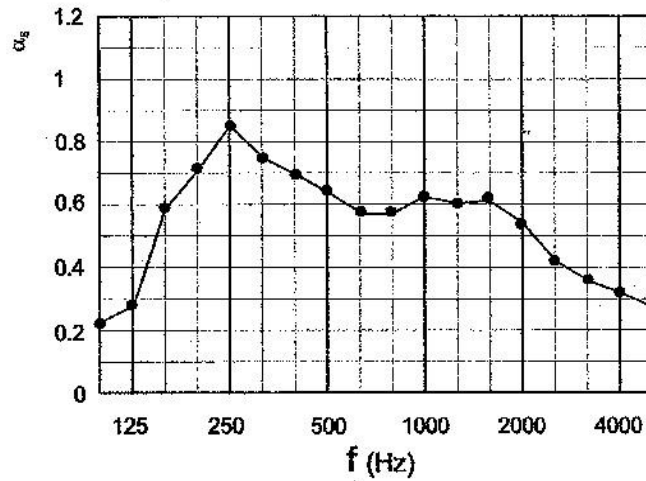

**$\alpha_m = 0,60$**

**NRC = 0,65**

Report AC-3-D4-11  
 Madrid, the 8<sup>th</sup> of March  
 2011

INSTITUTO DE ACUSTICA  
 CETEF Leonardo Torres Quevedo

Materials Laboratory